

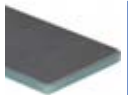





材料特性 Material properties

高性能耐磨材料作为滑动层结合高强度纤维增强的承载层；DURARUB® 材料适用于持续高静态和动态负载、相对较低滑动速度的应用，它们还适用于不可能或禁止常规润滑的应用。DURARUB® 材料为客户实现机械和设备零维护运行。

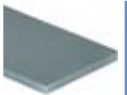
High-performance wear-resistant materials serve as sliding layers combined with high-strength fiber-reinforced load-bearing layers; DURARUB® materials are suitable for applications with consistently high static and dynamic loads, relatively low sliding speeds, and they are also suitable for applications where conventional lubrication is not possible or prohibited. DURARUB® materials enable maintenance-free operation of machinery and equipment for customers.

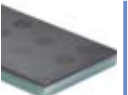
技术数据表 Technical data table

材料性能 Material properties	标准 Standard	单位 Unit	 DURARUB*11	 DURARUB*12	 DURARUB*21	 DURARUB*22	 DURARUB*33	 DURARUB*50
密度 Density	ISO1183	g/cm ³	1.95	1.90	2.10	2.10	1.80	1.56
极限PV值 Max. PV (dry)	ITS026	N/mm ² ×m/s	1.2	1.2	0.7	0.7	1.2	1.5
摩擦系数 Coefficient of friction	ITS025	μ	0.03~0.12	0.05~0.15	0.10~0.25	0.10~0.25	0.05~0.20	0.10~0.25
运行温度 Application temperature	ITS029	°C	-60/+120	-60/+120	-60/+120	-60/+120	-60/+120	-100/+250
最高速度 Max. Speed	ITS032	m/s	0.15	0.15	0.20	0.20	0.15	0.20
最大静载荷 Max. static load	ITS027	MPa	150	150	150	150	100	600
最大动载荷 Max. dynamic load	ITS028	MPa	75	75	10	10	60	110
线性热膨胀系数 Coefficient of thermal expansion	ISO11359	10 ⁻⁶ ×K ⁻¹	13	13	13	13	13	13
邵氏硬度 Shore hardness	ISO868	D	90	85	80	80	85	95
轴硬度 Shaft hardness		HB	≥180	≥180	≥180	≥180	≥180	≥400
轴表面粗糙度 Shaft surface finish		Ra	0.2-0.6	0.2-0.6	0.2-0.6	0.2-0.6	0.2-0.6	0.2-0.6

*ITS: CSB内部测试标准 CSB company's internal test standards.

**除非特殊说明测试温度为23°C Test temperatures are 23°C unless otherwise stated.

DURARUB®11 耐磨垫 Sliding plates

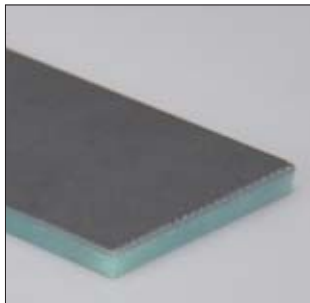

■ 材料结构

DR11 耐磨垫由两层组成，结合了低摩擦与高承载特性的滑动层和高强度玻璃纤维填充的衬背承载层。

滑动层由填充由固体润滑剂的环氧树脂与高耐磨纤维编织物组成，旨在确保良好的摩擦性能。

■ Material structure

DR11 sliding plates consist of two layers combining the excellent bearing properties of low-friction sliding layer with the high strength of a load carrying glass-fibre filled backing. The sliding layer consists of an epoxy resin filled with solid lubricants and high performance weaves, designed to ensure good tribological properties.

典型特征 Typical features

- 适用于干摩擦
- 高承载能力
- 低摩擦系数
- 高化学抗性
- 连续使用温度: -60/+120°C
- For dry applications
- High load capability
- Low friction coefficient
- good chemical resistance
- Continuous working temperature: -60/+120°C

标准规格 Standard specifications

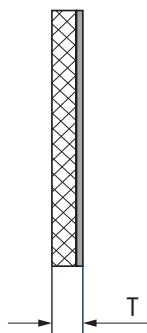
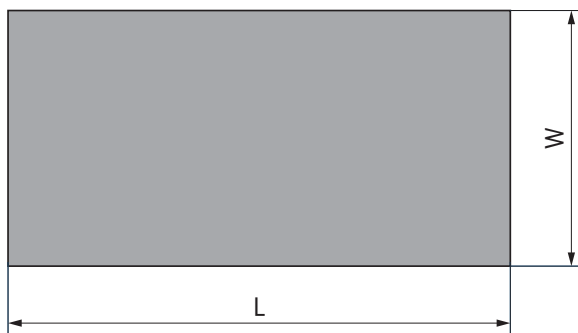

产品编码 Part No.:

DR11-055-0000-0000

L 长度 Length

W 宽度 Width

T 厚度 Thickness

材料 Material

产品编码 Part No.	T±0.15 厚度 ^① Thickness [mm]	W 最大宽度 Max. width [mm]	L 最大长度 Max. length [mm]
DR11-055-0000-0000	5.5	500	600
DR11-065-0000-0000	6.5	500	600
DR11-085-0000-0000	8.5	500	600
DR11-105-0000-0000	10.5	500	600
DR11-125-0000-0000	12.5	500	600
DR11-155-0000-0000	15.5	500	600
DR11-205-0000-0000	20.5	500	600

①更多厚度可根据要求 Other thicknesses available upon request.

DURARUB®12 耐磨垫片 Sliding washers



■ 材料结构

DR12 耐磨垫片由三层组成，结合了低摩擦与高承载特性的滑动层和高强度玻璃纤维填充的中心承载层。

滑动层由环氧树脂填充高耐磨纤维编织物组成，旨在确保良好的摩擦性能。

■ Material structure

DR12 sliding washers consist of three layers combining the excellent bearing properties of low-friction sliding layer with the high strength of a load carrying glass-fibre filled core layer. The core layer consists of an epoxy resin filled with high performance weaves, designed to ensure good tribological properties.

典型特征 Typical features

- 适用于干摩擦
- 高承载能力
- 低摩擦系数
- 高化学抗性
- 连续使用温度: -60/+120°C
- For dry applications
- High load capability
- Low friction coefficient
- good chemical resistance
- Continuous working temperature: -60/+120°C

标准规格 Standard specifications

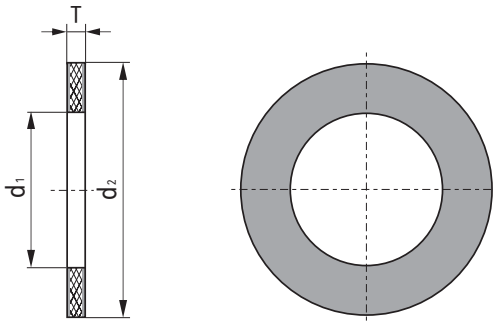

产品编码 Part No.:

DR12W-1020-020

- T 厚度 Thickness
- d₂ 外径 Outer diameter
- d₁ 内径 Inner diameter
- 材料 Material

产品编码 Part No.	T ^{±0.15} ① [mm]	d ₁ ^{+0.25} [mm]	d _{2-0.25} [mm]
DR12W-1020-020	2.0	10	20
DR12W-1224-020	2.0	12	24
DR12W-1426-020	2.0	14	26
DR12W-1530-020	2.0	15	30
DR12W-1630-020	2.0	16	30
DR12W-1832-020	2.0	18	32
DR12W-2036-020	2.0	20	36
DR12W-2238-020	2.0	22	38
DR12W-2442-020	2.0	24	42
DR12W-2546-020	2.0	25	46
DR12W-2640-020	2.0	26	40
DR12W-2644-020	2.0	26	44
DR12W-2848-020	2.0	28	48

产品编码 Part No.	T ^{±0.15} ① [mm]	d ₁ ^{+0.25} [mm]	d _{2-0.25} [mm]
DR12W-3050-025	2.5	30	50
DR12W-3254-025	2.5	32	54
DR12W-3560-025	2.5	35	60
DR12W-3862-025	2.5	38	62
DR12W-4065-025	2.5	40	65
DR12W-4266-025	2.5	42	66
DR12W-4570-025	2.5	45	70
DR12W-4874-025	2.5	48	74
DR12W-5075-030	3.0	50	75
DR12W-5278-030	3.0	52	78
DR12W-5685-030	3.0	56	85
DR12W-6085-030	3.0	60	85
DR12W-6290-030	3.0	62	90

①更多厚度可根据要求 Other thicknesses available upon request.

DURARUB®21 耐磨垫 Sliding plates

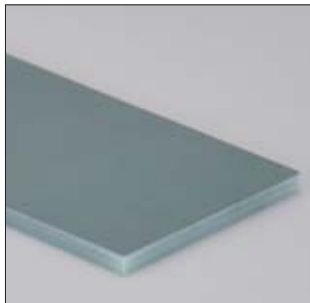

■ 材料结构

DR21 耐磨垫由两层组成，结合了低摩擦与高承载特性的滑动层和高强度玻璃纤维填充的衬背承载层。

滑动层由填充摩擦改良的PTFE带材组成，旨在确保良好的摩擦性能与较低的启动摩擦力。

■ Material structure

DR21 sliding plates consist of two layers combining the excellent bearing properties of low-friction sliding layer with the high strength of a load carrying glass-fibre filled backing. The sliding layer consists of a fluoroplastic filled with solid lubricants, designed to ensure good tribological properties and lower starting friction force.

典型特征 Typical features

- 适用于干摩擦
- 可配合硬化表面铝轴
- 低启动摩擦力
- 高化学抗性
- 连续使用温度：-60/+120°C
- For dry applications
- Available hardened surface aluminum shafts
- Low starting friction force
- good chemical resistance
- Continuous working temperature: -60/+120°C

标准规格 Standard specifications

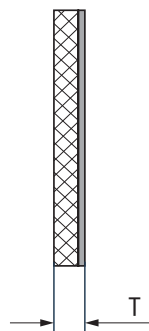
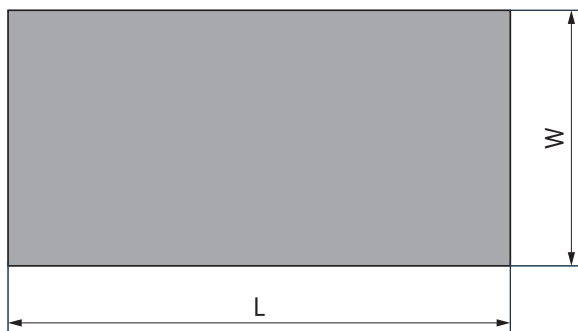

产品编码 Part No.:

DR21-055-0000-0000

L 长度 Length

W 宽度 Width

T 厚度 Thickness

材料 Material

产品编码 Part No.	T±0.15 厚度 ^① Thickness [mm]	W 最大宽度 Max. width [mm]	L 最大长度 Max. length [mm]
DR21-055-0000-0000	5.5	300	600
DR21-065-0000-0000	6.5	300	600
DR21-085-0000-0000	8.5	300	600
DR21-105-0000-0000	10.5	300	600
DR21-125-0000-0000	12.5	300	600
DR21-155-0000-0000	15.5	300	600
DR21-205-0000-0000	20.5	300	600

①更多厚度可根据要求 Other thicknesses available upon request.

DURARUB®22 耐磨垫片 Sliding washers



■ 材料结构

DR22 耐磨垫片由三层组成，结合了低摩擦与高承载特性的滑动层和高强度玻璃纤维填充的中心承载层。

滑动层由填充摩擦改良的PTFE带材组成，旨在确保良好的摩擦性能与较低的启动摩擦力。

■ Material structure

DR22 sliding washers consist of three layers combining the excellent bearing properties of low-friction sliding layer with the high strength of a load carrying glass-fibre filled core layer. The sliding layer consists of a fluoroplastic filled with solid lubricants, designed to ensure good tribological properties and lower starting friction force.

典型特征 Typical features

- 适用于干摩擦
- 可配合硬化表面铝轴
- 低启动摩擦力
- 高化学抗性
- 连续使用温度: -60/+120°C
- For dry applications
- Available hardened surface aluminum shafts
- Low starting friction force
- good chemical resistance
- Continuous working temperature: -60/+120°C

标准规格 Standard specifications

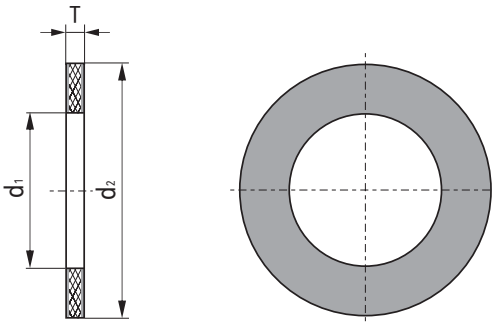

产品编码 Part No.:

DR22W-1020-020

- T 厚度 Thickness
- d₂ 外径 Outer diameter
- d₁ 内径 Inner diameter
- 材料 Material

产品编码 Part No.	T ^{±0.15} ① [mm]	d ₁ ^{+0.25} [mm]	d ₂ ^{-0.25} [mm]
DR22W-1020-020	2.0	10	20
DR22W-1224-020	2.0	12	24
DR22W-1426-020	2.0	14	26
DR22W-1530-020	2.0	15	30
DR22W-1630-020	2.0	16	30
DR22W-1832-020	2.0	18	32
DR22W-2036-020	2.0	20	36
DR22W-2238-020	2.0	22	38
DR22W-2442-020	2.0	24	42
DR22W-2546-020	2.0	25	46
DR22W-2640-020	2.0	26	40
DR22W-2644-020	2.0	26	44
DR22W-2848-020	2.0	28	48

产品编码 Part No.	T ^{±0.15} ① [mm]	d ₁ ^{+0.25} [mm]	d ₂ ^{-0.25} [mm]
DR22W-3050-025	2.5	30	50
DR22W-3254-025	2.5	32	54
DR22W-3560-025	2.5	35	60
DR22W-3862-025	2.5	38	62
DR22W-4065-025	2.5	40	65
DR22W-4266-025	2.5	42	66
DR22W-4570-025	2.5	45	70
DR22W-4874-025	2.5	48	74
DR22W-5075-030	3.0	50	75
DR22W-5278-030	3.0	52	78
DR22W-5685-030	3.0	56	85
DR22W-6085-030	3.0	60	85
DR22W-6290-030	3.0	62	90

①更多厚度可根据要求 Other thicknesses available upon request.

DURARUB®33 耐磨垫 Sliding plates

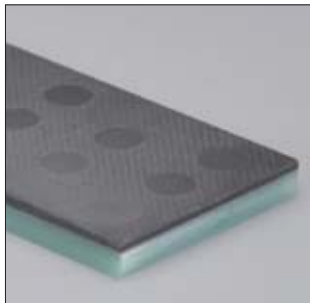

■ 材料结构

DR33耐磨垫由两层组成，结合了低摩擦与高承载特性的滑动层和高强度玻璃纤维填充的衬背承载层。

滑动层由填充高强度固体润滑柱的环氧树脂与高耐磨纤维编织物组成，旨在确保极高承载性能与良好的摩擦性能。

■ Material structure

DR33 sliding plates consist of two layers combining the excellent bearing properties of low-friction sliding layer with the high strength of a load carrying glass-fibre filled backing. The sliding layer consists of an epoxy resin filled with high strength solid lubricant columns and high performance weaves, designed to ensure high load and good tribological properties.

典型特征 Typical features

- 适用于干摩擦、油脂或水下应用
- 不含氟、硅材料
- 极好的尺寸稳定性
- 高承载能力
- 低摩擦系数
- 高化学抗性
- 滑动层可加工
- 连续使用温度: -60/+120°C
- For dry, oil, grease or underwater applications
- Fluorine and silicon free
- Excellent dimensional stability
- High load capability
- Low friction coefficient
- Good chemical resistance
- Sliding layer machined available
- Continuous working temperature: -60/+120°C

标准规格 Standard specifications

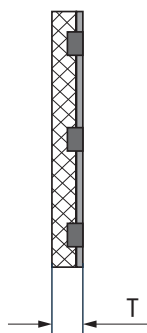
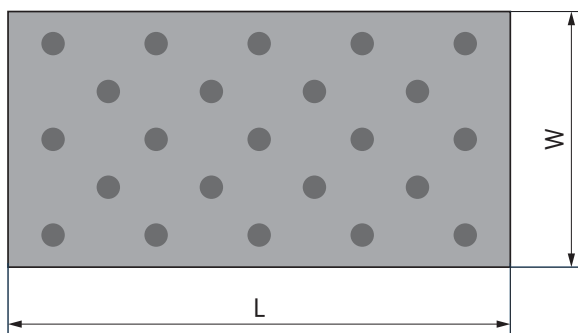

产品编码 Part No.:

DR33-050-0000-0000

L 长度 Length

W 宽度 Width

T 厚度 Thickness

材料 Material

产品编码 Part No.	T ^{±0.15} 厚度 ^① Thickness [mm]	W 最大宽度 Max. width [mm]	L 最大长度 Max. length [mm]
DR33-050-0000-0000	5.0	500	600
DR33-060-0000-0000	6.0	500	600
DR33-080-0000-0000	8.0	500	600
DR33-100-0000-0000	10.0	500	600
DR33-120-0000-0000	12.0	500	600
DR33-150-0000-0000	15.0	500	600
DR33-200-0000-0000	20.0	500	600

①更多厚度可根据要求 Other thicknesses available upon request.

DURARUB®50 耐磨垫 Sliding plates

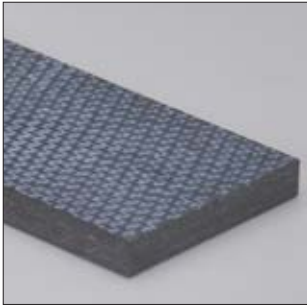

■ 材料结构

DR50滑动垫仅由滑动层组成，结合了低摩擦滑动层的优异承载性能和高强度。滑动层含有特殊碳纤维织物填充PEEK树脂，旨在确保良好的机械与摩擦学性能。

■ Material structure

DR50 sliding plates consists only of a sliding layer, combining the excellent load performance and high strength of a low-friction sliding layer. The sliding layer consists of a special carbon fiber fabric filled with PEEK resin, designed to ensure good mechanical and tribological properties.

典型特征 Typical features

- 适用于干摩擦、油脂或水下应用
- 不含氟、硅材料
- 极好的尺寸稳定性
- 高承载能力
- 高化学抗性
- 滑动层可加工
- 连续使用温度：-100/+250°C
- For dry, oil, grease or underwater applications
- Fluorine and silicon free
- Excellent dimensional stability
- High load capability
- Good chemical resistance
- Sliding layer machined available
- Continuous working temperature: -100/+250°C

标准规格 Standard specifications

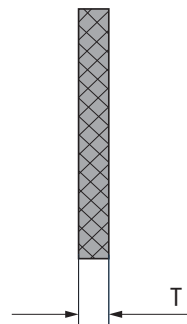
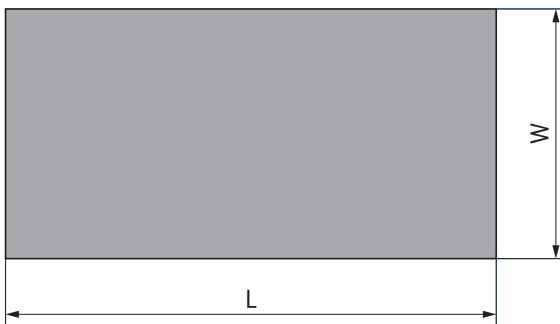

产品编码 Part No.:

DR50-010-0200-0400

- L 长度 Length
- W 宽度 Width
- T 厚度 Thickness
- 材料 Material

产品编码 Part No.	T 厚度 Thickness [mm]	W 最大宽度 Max. width [mm]	L 最大长度 Max. length [mm]
DR50-010-0200-0400	1.0	200	400
DR50-015-0200-0400	1.5	200	400
DR50-020-0200-0400	2.0	200	400
DR50-025-0200-0400	2.5	200	400
DR50-030-0200-0400	3.0	200	400
DR50-050-0600-1000	5.0	600	1000
DR50-060-0600-1000	6.0	600	1000

产品编码 Part No.	T 厚度 Thickness [mm]	W 最大宽度 Max. width [mm]	L 最大长度 Max. length [mm]
DR50-080-0600-1000	8.0	600	1000
DR50-100-0600-1000	10.0	600	1000
DR50-120-0600-1000	12.0	600	1000
DR50-150-0600-1000	15.0	600	1000
DR50-200-0600-1000	20.0	600	1000
DR50-250-0600-1000	25.0	600	1000
DR50-300-0600-1000	30.0	600	1000

*所有尺寸与公差根据需求 All dimensions and tolerances upon request.

使用 M8 螺钉安装说明 Installation with M8 countersunk screws

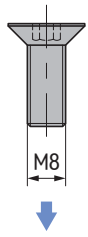
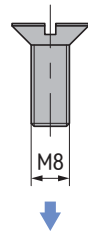
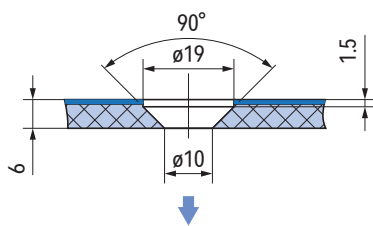
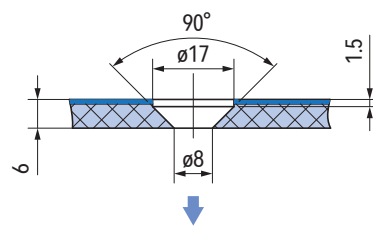
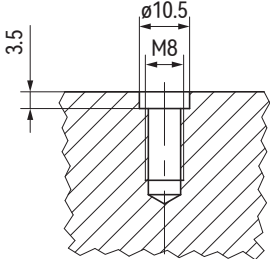
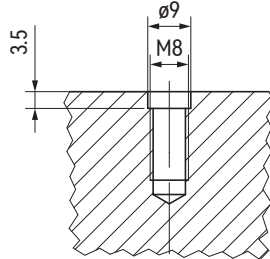
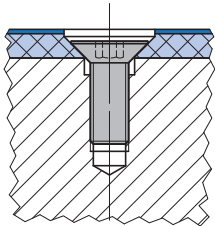
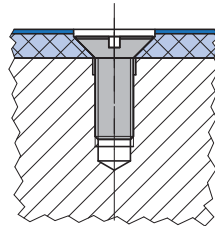
<p>M8 内六角沉头螺钉 (符合 EN ISO 10642 标准) 也适用于十字槽沉头螺钉 Countersunk socket screw M8 (according to EN ISO 10642) also valid for torx screw</p>	<p>M8 一字槽沉头螺钉 (符合 ISO 2009 标准) Slotted countersunk screw M8 (according to ISO 2009)</p>
<p>A1</p> 	<p>B1</p> 
<p>DURARUB® 耐磨垫 Sliding plates</p>	<p>DURARUB® 耐磨垫 Sliding plates</p>
<p>A2</p> 	<p>B2</p> 
<p>基础材料 Base material</p>	<p>基础材料 Base material</p>
<p>A3</p> 	<p>B3</p> 
<p>安装后的DURARUB® 耐磨垫 DURARUB® sliding plates after installation</p>	<p>安装后的DURARUB® 耐磨垫 DURARUB® sliding plates after installation</p>
<p>A4</p> 	<p>B4</p> 
<p>安装Mounting 安装时, 使用金属粘合剂“Loctite 243”(中等强度) 或“Loctite 278”(高强度) 固定螺钉。必须遵守工作温度限制和制造商的详细说明。 During mounting, secure the screws with metal adhesive "Loctite 243" for intermediate strength or Loctite 278" for high-strengthbolting. The operating temperature limits and manufacturer's details must be observed.</p>	